

B. D. NEDELJKOVIĆ, M. S. TRIFUNOVIĆ, S. NIKEZIĆ

Composite for Making of Friction Elements With Metal Matrix on the Basis of Copper-Zinc Alloy

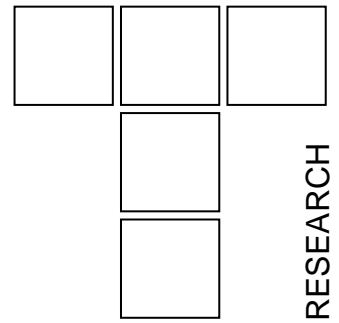

In this paper we presented the results of the testing of tribological and mechanical features of laboratory composites, on basis of CuZn37, strengthened by dispersion. This composite was made by casting, during which the matrix alloy CuZn37 was strengthened by particles of steel powder of certain chemical content. The got results indicate that the idea of making a projected type of composite is an interesting one and that we should continue working on finding optimal combination of metal matrix composite (MMC), which could be used in making friction elements of improved tribological and mechanical characteristics.

Keywords: composite, ingot metallurgy, friction elements, tribological features

1. INTRODUCTION

Copper and Zinc alloys, which belong to a group of special types of brass, containing copper (from 58 to 63 percents by weight), are easily treated and have good mechanical characteristics, so they are used for making friction elements, such as: elements for speed synchronization (synchronizers), elements for power transmission during rotation and other (Biak 3/61, Biak 3/58, Fiat - St. 53521).

For more demanding friction elements special types of brass are produced containing even up to 70 % by weight of copper (NE-Metallhalbzeug Diehl-Legierung 470), featuring increased hardness and high resistance to wearing. Since they are expensive, some other, alternative, solutions are looked for.

One of methods for improving mechanical and tribological features of these materials could be the dispersion strengthening of matrix on basis of copper-zinc alloys with particles of suitable type, granulation (size in μm) and concentration (percentage by weight according to weight of metal insert).

When choosing type of strengthener, among other things, we considered their mechanical and tribological features (crucial for exploitation

conditions to which these friction elements are exposed), compatibility of components present in composite material, specific weights (it is very important that there is not a great difference in specific weights of matrix and particles, so as to avoid segregation of particles in the melt during process of strengthening) and other.

The detailed experiment includes the following: preparation of components, making of composite samples by casting, preparation of samples for testings and comparative testing of structural, mechanical, tribological and technological features of basic alloy samples and of generated composite samples.

In this paper we presented the results which are only a small part of much wider experimental program.

2. EXPERIMENTAL PART

The basic objective of this experiment was to create in a laboratory a composite with dispersion strengthened matrix based on CuZn37 alloy and with particles of steel powder (with more than 0,7%C and more than 2,0%Ni), which should have the following main characteristics: relatively high coefficient of friction and relatively high resistance to crumbling during relative gliding (crumbling during process of wearing), that is, increased hardness.

It is well-known that there are many techniques of generating composite with metal matrix, and among

Dr Branislav Nedeljković, B.Sc.

Zastava automobili, a.d. Central Laboratory dpt.

M. S Trifunović, Zastava automobili

Srdjan Nikezić, B. Econ.

Zastava automobili, a.d. "Spare parts" dpt.

them the whirling casting method conducted in adequate equipment has a special place. Also, regarding making this kind of composite, some modern methods of powder metallurgy lately gained advantage in comparison with standard procedures of ingot metallurgy (melting and casting procedures). In our work, we faced the basic problem referring to device, that is, to the method of generating samples of projected composites. Thus, we tried to generate projected castings of metal composite, using the simplified experiments of ingot metallurgy.

2.1 Composition of initial components is presented in tables 1 and 2

Table 1. Chemical composition of applied CuZn37 alloy, percentage by weight

Cu	Zn	Al	Fe	Sb	Ni	Pb	Sn	volume kg/dm ³
62,85	37,96	0,023	0,09	0,092	0,25	0,12	0,07	8,4 10 ³

Table 2. Chemical composition of strenghtened phase, percentage by weight

Steel powder*	>0,70	Ni>2,0	Mo	Cu	Fe	Other	Average volume, kg/dm ³
	0,86	2,06	0,52	0,8	Remnant to 100%	-	7,8 10 ³

*The strenghtened phase is prepared in form of particles with granulation $G < 15 \mu\text{m}$ and in concentration of 10 and 15 percents by weight. The size of particles was identified by separation conducted with sieve having different number of meshes in one unit of area.

2.2 Technology of generating metal matrix composite

Since the number of pages of this paper is limited, we cannot share with you all the details of the conducted experiment, but we will tell you the most important things about it so that you could get the general picture about it. In the indicated conditions, our main task in the initial phase of this experiment was to input particles into the melted matrix alloy, without paying much attention to the fact that they will not be evenly distributed (and we are aware of the fact that when designing and making these materials we aim at generating homogenous composites without pores and particles segregation).

We had both technical and economical reasons for doing so, since it enabled us to move the centre of

the experiment closer to its basic objective indicated in the beginning.

As a matter of fact, we paid attention mostly to testing the composite main exploitation characteristics (wear resistance and hardness), with which the most important thing is to notice trend and global figures indicating their changes, in which case, the distribution of particles in composite does not have to be the optimum one. Preliminary test results may, in most cases, in an efficient and rational way indicate whether a certain technical-technological idea is correct or not and pave the way for further research.

The description of the composite casting procedure will follow. We charged the mould for melting, which is similar to casting mould, only larger: $H=70\text{mm}$, and $\Phi_u=50\text{mm}$) with matrix CuZn37 alloy in granules, and then we covered the surface of the metal insert with graphite powder (instead of it, we can use borax p.a 99,98 %), so as to avoid zinc oxidation, which happened during test experiments and had negative metallurgical and technological effects on the quality of casting. The mould for melting prepared in such a way, is, after appropriate preheating, put into laboratory electricresistance furnace, whose temperature and nitrogen atmosphere can be regulated. Into adequately prepared melted basic alloy, at the tempriture of $t \approx 980 \text{ }^\circ\text{C}$, we added regularly preheated particles of strengthener (of regulated granulation and concentration) and we conducted the mixing of composite suspension so as to avoid gathering of particles in the melt. Quickly after that the composite suspension was poured from mould for melting to preheated casting mould, whose shape and dimensions are shown in figure 1. Also, in appropriate way, we managed to conduct in casting mould the additional mixing of the composite lasting 2-3 minutes, since the strengthening process didn't last long.

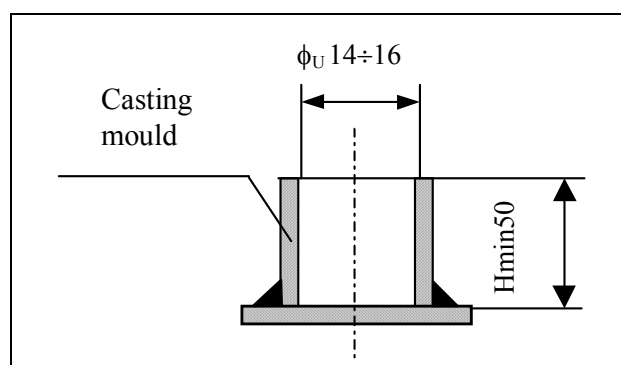

Figure 1. Draft of casting mould made of

Cooling of castings until their temperature reaches room temperature was conducted in a room without air streaming. The whole casting process per one charging lasted about 30 min. (preheating of the charged moulds for melting and for casting).

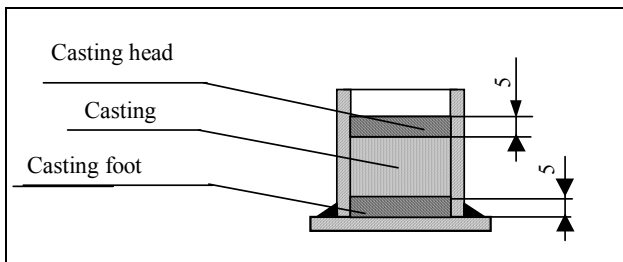

Figure 2. Draft of mould with casting steel pipe with welded bottom side of MMC

We made composite-casting in a shape of roll (D=16mm and H=40mm) in the above described manner. We took the castings from casting moulds, meant for one use only, by using suitable methods of cutting treatment. Then we made of composite-castings, as well as of casted matrix alloy used as a reference sample, samples suitable for further work. Before making standard samples for the planned tests, we conducted some metallographic research work on composite roll castings in their horizontal planes, and in their vertical planes also (parallel to the casting longitudinal axis). Using qualitative metallographic analysis we realized that particles are present in their metal basis, but unevenly distributed, in almost 50% of cases. Because of that, we selected only representative composite castings for making standard samples-pins, which will be further on used in the tests described in this paper.

2.3 Comparative testings of composite and matrix alloy samples

It is a well known fact that the control of production process and of wanted (projected) features of material is most efficiently achieved by controlling microstructure of material. (using qualitative and quantitative metallographic analysis). Bearing in mind that the technical conditions of this experiment are not perfect, we excluded the planned metallographic analysis. We prepared in a standard way the samples for qualitative analysis using optical microscope.

Figures 3 to 5 show the microphotographs of unetched composite samples with different composition regarding steel powder particles, with 100% of blow up. Figure 3 shows microstructure of the composite casting with 10% of steel powder from which we prepared a pin sample, marked as tr

8 a, for undergoing hardness and tribological tests. Figure 4 and 5 show the microstructure of the composite with 15% of strengthening component, although the presence of particles segregation is visible in the sample marked as tr 6.

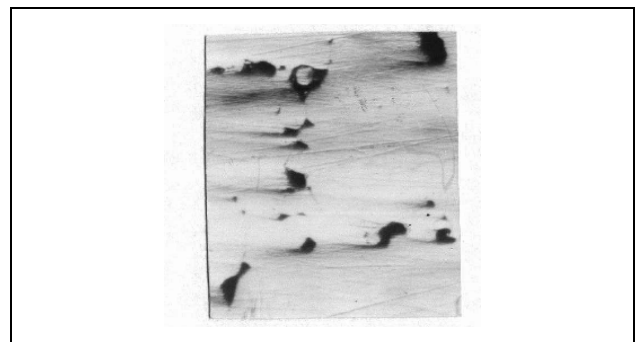

Figure 3. Microstructure CuZn37 - steel powder composite 10 % by weight (sample - PIN, tr 8a)

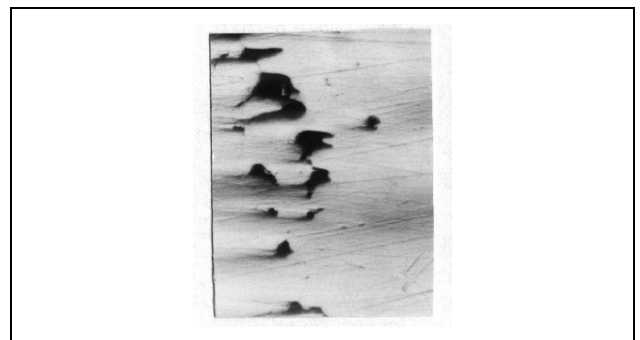

Figure 4. Microstructure CuZn37 - steel powder composite (15 % by weight) (sample -PIN, tr6)



Figure 5. Microstructure CuZn37 steel powder composite (15. % by weight) (sample -PIN, tr 10)

For testing tribological features, we prepared pin-samples from castings, the shape and dimensions of which are presented in figure 6. During experiments described in this paper we made the linear contact between the pin and the disc (figure 7) over the pin surface, the roughness of which is marked in the previous picture.

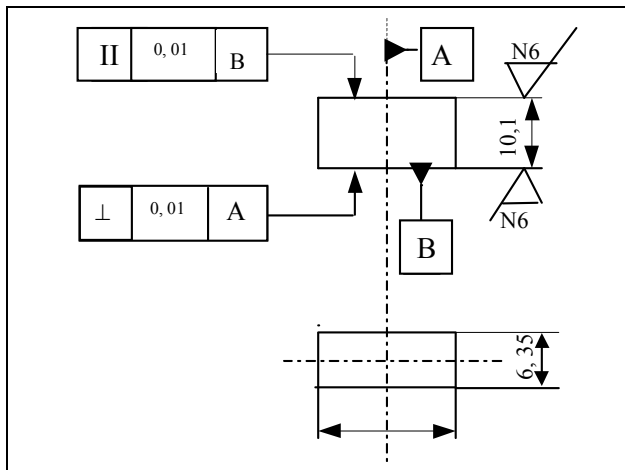

Figure 6. PIN'S looks and dimensions

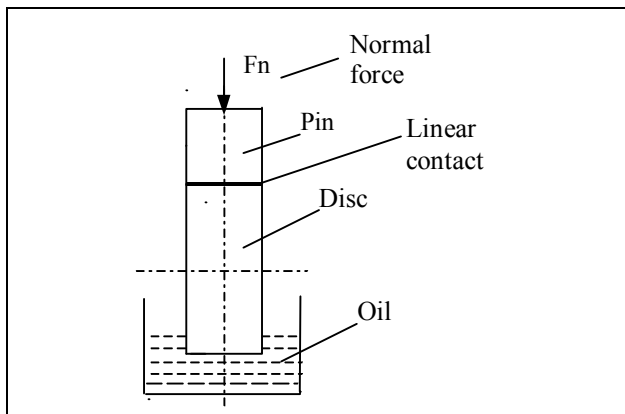

Figure 7. Geometry of the contact on tribometer TPD-93

Testing of tribological characteristics on the prepared pins was conducted in laboratory for tribology at Mechanical Faculty in Kragujevac. Before that, with optical microscope with suitable blow up (min 100 times), we identified on the surface of the pins, the roughness class of which is N6, spots with different concentration of strengthener particles in one unit of area and we marked them appropriately.

During tribological testing, after implementing suitable alignments (positioning of the pin and the disc) we made contact between disc and pin in the marked spots, that is, near them, by which we noted tribological characteristics of composites containing various particles concentration. The tribological characteristics of material were tested by tribometer TPD - 93. In this experiment we used the gauges and computer equipment regulated by Standard. Samples (pins) of composites and basic alloy CuZn37 were tested under the same conditions:

Normal force $F=500$ N, time of contact $t=1800$ sec., disc diameter $D=35$ mm, disc hardness 62 HRC, $n=1100$ rev/min.; lubricant: hipoid "Mentol"; contact between disc and pin: line.

Measuring of width of wearing track left on the surface was conducted by universal microscope UIM-21. We measured the hardness HV1 and HV0,5 (6 measuring spots) immediately close to this wearing region, on the pins located on its both sides. All composite samples have higher hardness values than the matrix alloy, which is illustrated in table 3.

3. RESULTS AND DISCUSSION

In table 3 we presented the results of comparative tests on hardness and main characteristics of wearing resistance - friction coefficient and wearing region width of composite and matrix alloy samples.

As you can see, the hardness of composites rises, as expected, because a cluster of insoluble particles of steel powder located in alloy CuZn37 creates a structure which impedes movement of dislocated elements and in that way increases the hardness of material. The moving of dislocated elements is mostly impeded by second phase dispersion particles, so it is understandable that as the weight percentage of steel powder particles rises, the hardness rises as well.

Table 3 Marks, materials and average hardness value, friction coefficient and width of wearing region on tested samples

Sample mark	Material	Hardness		Friction coefficient	Width of wearing region, mm
		HV 1	HV 0,5		
tr 4	CuZn37	98	117	0,0272	1,847
tr 4a		93	106	0,0214	1,896
tr 8 a	10 % by weight, steel powder	117	119	0,0233	1,719
tr 6	15 % by weight, steel powder	112	136	0,0415	1,966
tr 10	15 % by weight, steel powder	133	152	0,0316	1,413

It is well known that there is relatively high degree of correlation between mechanical characteristics of material (firstly hardness and strength of material) and main characteristics of wear resistance (friction coefficient and width of wearing region). Although hardness of material effects friction coefficient, we still have not defined the reliable relationship between these characteristics. The information from table 3 show that with rise of hardness there is tendency that friction coefficient will rise too, while width of wearing region will decrease. (that is wear resistance) Medium value of friction coefficient of composite samples grows in comparison with adequate value of basic alloy. Width of wearing region on composite pins in most cases has smaller

values when compared to values relating to matrix alloy. The exception to this rule is the sample of pin tr 6, which has the highest medium value of friction coefficient, but however its medium value of wearing region width is higher than the one of matrix alloy. This can be explained by microphotograph (figure 4) on which one can see that there is segregation of particles, and conclude that in this particular case an abrasive wearing is dominant, which causes extraction of steel powder particles, and all that, when exposed to friction, encourage the wearing of softer surface.

Changing of friction coefficient in time intervals are presented to you for samples tr 4, tr 6 and tr 10. (figures 8, 9 and 10).

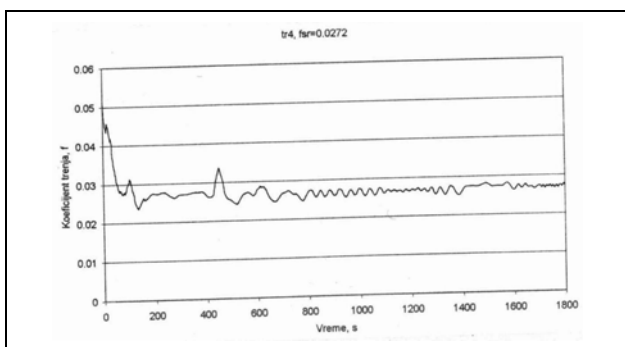

Figure 8. Changing of friction coefficient during the contact casting for 1800 sec. (CuZn37 – sample tr4)

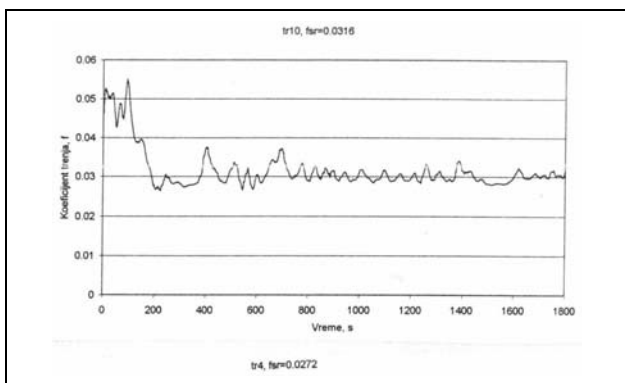

Figure 9. Changing of friction coefficient during the contact casting for 1800 sec. (composite – sample tr6)

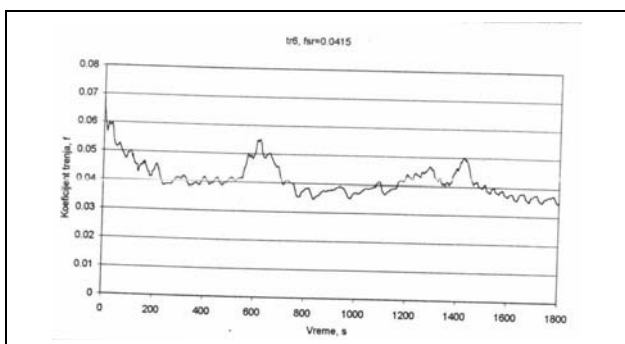

Figure 10. Changing of friction coefficient during the contact casting for 1800 sec. (composite sample tr10)

4. CONCLUSION

Based on the testing of tribological and mechanical characteristics conducted on the mentioned samples of composite CuZn37-steel powder (of regulated composition), with different by weight composition of steel powder, made by simplified procedure of ingot metallurgy in laboratory conditions, we can conclude the following:

- the idea of projected kind of composite is an interesting one and we should continue working on finding an optimal combination of this kind of composite, which could then be used for making of friction elements with improved tribological and mechanical characteristics
- the results of this preliminary research work could be used as the basis for working on making dispersion strengthened composites on basis of copper zinc alloy with an addition of a suitable type, granulation and concentration of strengthener.
- In future experiments it is necessary to modify the technology of making composites by construction and of making necessary devices with a view to getting homogenous composite without pores and segregations.

REFERENCES

- [1.] Michal Hebda, Andrej Wachal, TRYBOLOGIA, Wydawnictwa, Naukowo - Techniczne, Warszawa, 1980.
- [2.] Vladimir Ogarević, "Fatigue Behavior and Life Predictions of a Particle Reinforced Metal Matrix Composite at Room and Elevated Temperatures", doktorska disertacija, Univerzitet Ajove, Ajova, SAD, 1992.
- [3.] Fishman, S.G., Dhingra, A.K. (ed), "Cast Reinforced Metal Composites", ASM international, USA, 1988, 77-81
- [4.] Babić M., Jeremić B: Specifičnosti ispitivanja trenja i habanja na tribometrima, Tribologija u industriji broj 3, septembar (1992), Kragujevac, 77-79.
- [5.] D. Stanković, S. Marković, V. Jokanović: Metode izrade metalmatičnih kompozita livenjem, Livarstvo, No 193, Beograd, 1994.

[6.] Nedeljković B. : Uticaj mikrostrukture na mašinsku obradivost i tribološka svojstva sivog liva, doktorska disertacija, Beograd, juni 1996.

[7.] Hammoun, D., Modern Casting, September 1990, p.p 27-30